

aerie

Washington, DC



50 Halstead Blvd.
Suite 17
Zellienople, PA 16063

Tel 724.452.8699
Fax 724.452.8629

www.signinnovation.com



John Koenig, Project Manager
Johnk@SignInnovation.com



- 1 Cover Page
- 2 Site Plan
- 3 Existing Storefront Elevations
- 4 Interior Storefront Sign Details
- 5 Proposed Sign Rendering



Aerie
3235 M St NW,
Washington, DC 20007

Google Maps

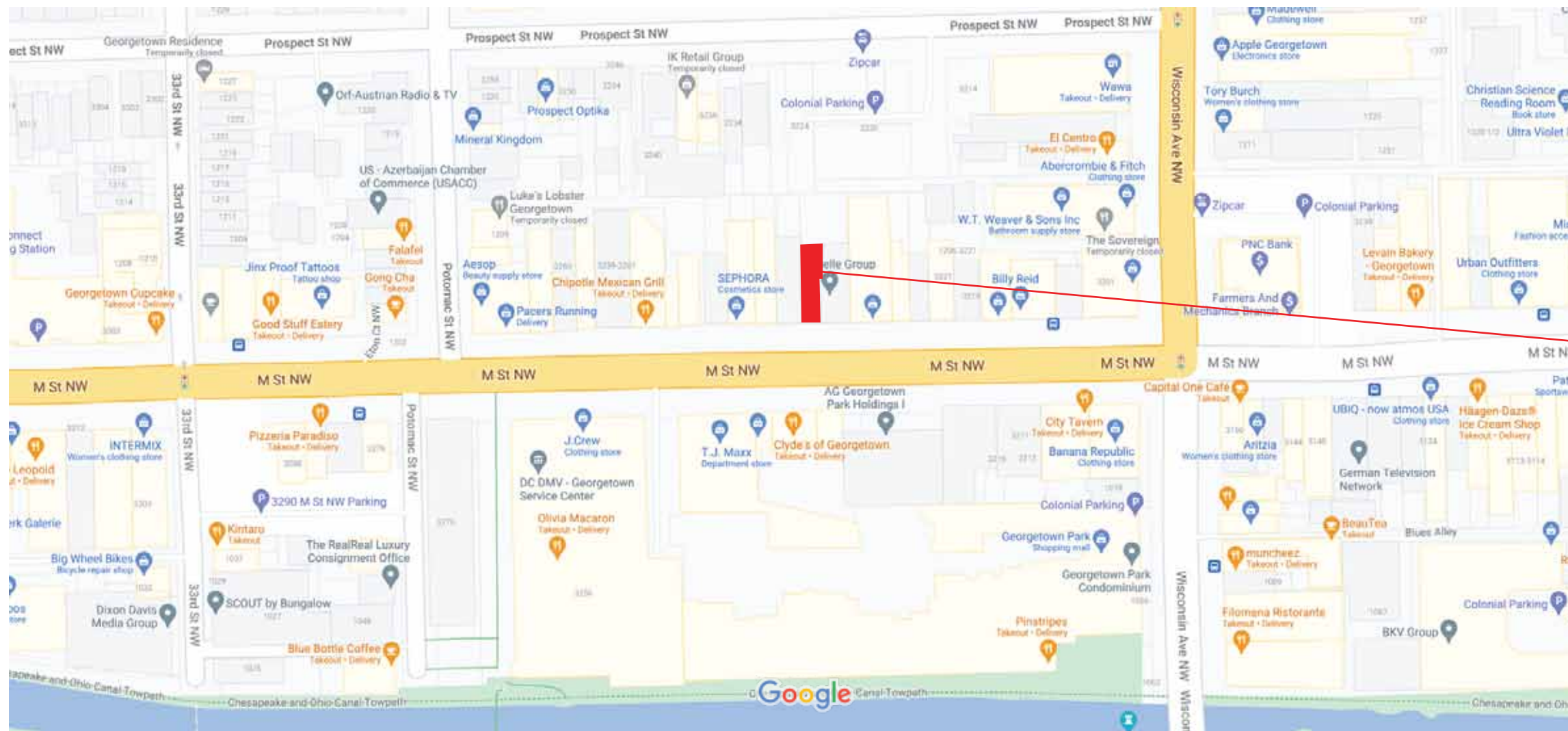

Aerie
 3235 M St NW.
 Washington, DC 2007

Previous Tenant: AllSaints

Map data ©2021 Google 50 ft



50 Halstead Blvd.
 Suite 17
 Zellenople, PA 16063

Tel 724.452.8699
 Fax 724.452.8629

www.signinnovation.com

John Koenig, Project Manager
 Johnk@SignInnovation.com

- 1 Cover Page
- 2 Site Plan
- 3 Existing Storefront Elevations
- 4 Interior Storefront Sign Details
- 5 Proposed Sign Rendering

Aerie
 3235 M St NW,
 Washington, DC 20007

EXISTING BULB LIT LETTERS BEHIND TRANSM GLASS TO BE REMOVED AND REPLACED WITH PROPOSED AERIE SIGN



50 Halstead Blvd.
Suite 17
Zellenople, PA 16063
Tel 724.452.8699
Fax 724.452.8629

John Koenig, Project Manager
Johnk@SignInnovation.com

- 1 Cover Page
- 2 Site Plan
- 3 Existing Storefront Elevations
- 4 Interior Storefront Sign Details
- 5 Proposed Sign Rendering

Aerie
3235 M St NW,
Washington, DC 20007



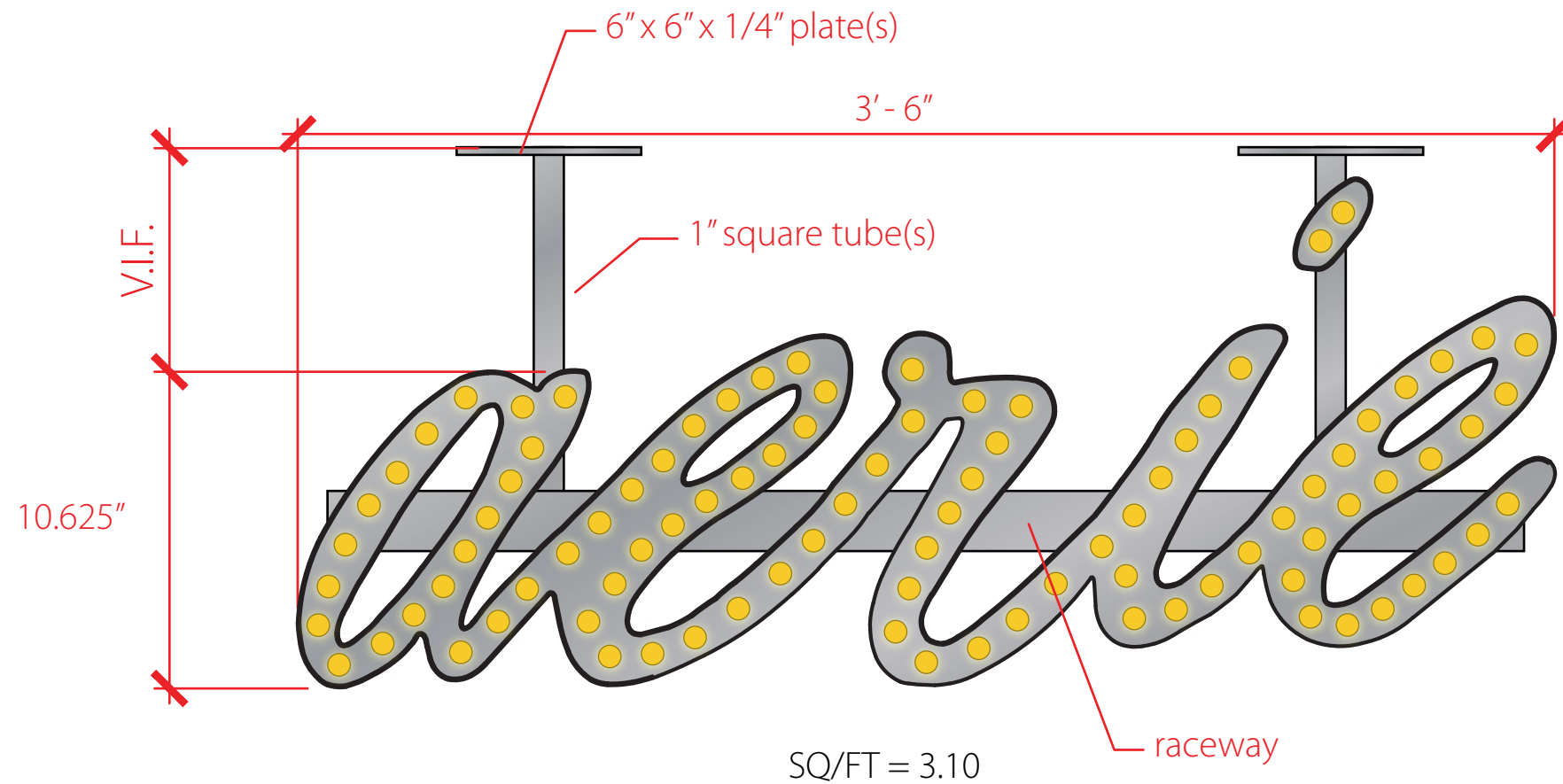
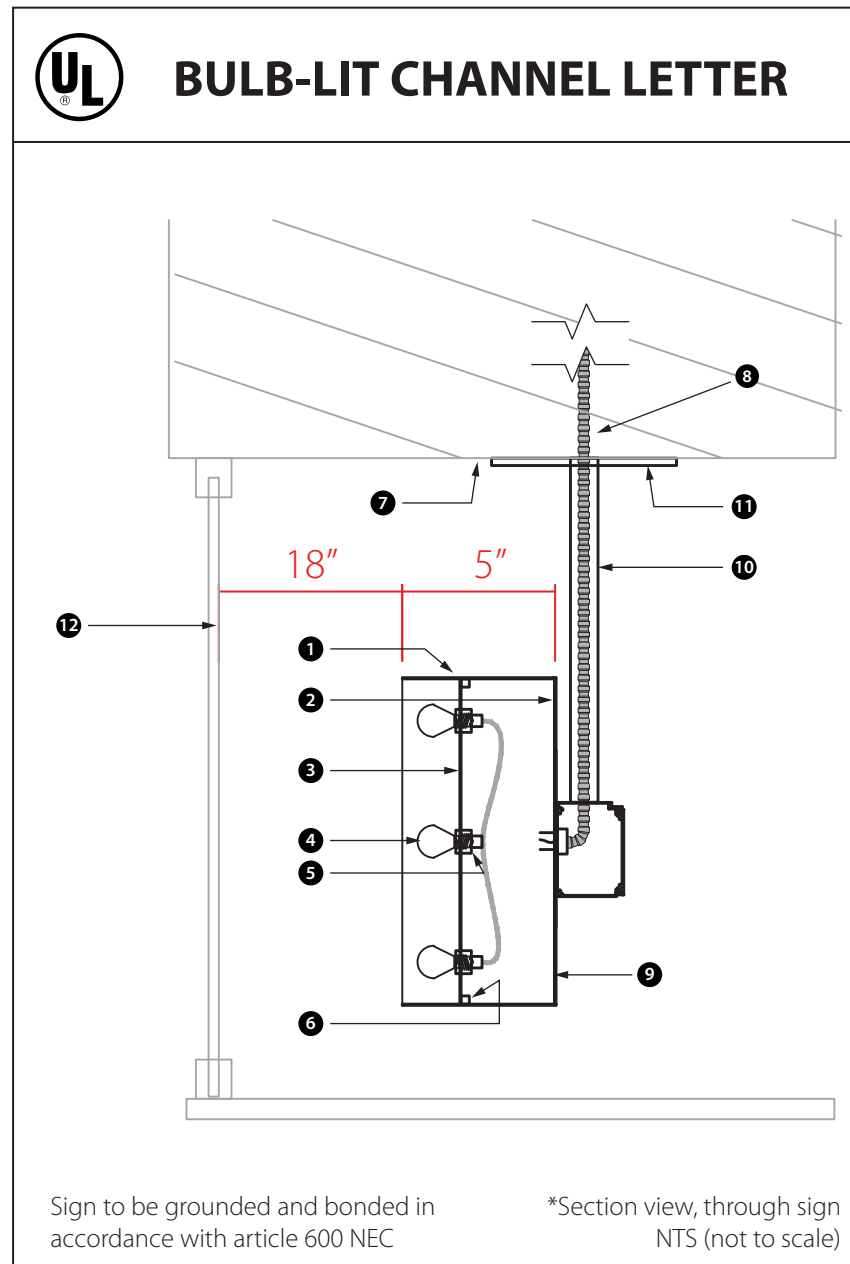

NOTE: Storefront to be installed on INTERIOR. Set back approx. 18" from storefront glass.

NUMBER KEY

- 1 Aluminum Returns (mill finish)
- 2 Aluminum Back (mill finish)
- 3 Aluminum False Back (mill finish)
- 4 GE C7 LED Bulb LED0.5C7/C/CD2
- 5 Candelabra E12 Socket
- 6 Recessed Flat Head Screws
- 7 Existing ceiling with blocking by others
- 8 Dedicated 120v primary electric to be run by others
- 9 2" x 2" raceway (mill finish)
- 10 1" support rods (mill finish)
- 11 1/4" mounting plates
- 12 Existing Transom Glass

COLORS

-  Aluminum Mill Finish



50 Halstead Blvd.
Suite 17
Zellienople, PA 16063
Tel 724.452.8699
Fax 724.452.8629

John Koenig, Project Manager
Johnk@SignInnovation.com

- 1 Cover Page
- 2 Site Plan
- 3 Existing Storefront Elevations
- 4 Interior Storefront Sign Details
- 5 Proposed Sign Rendering

Aerie
3235 M St NW,
Washington, DC 20007



NOTE: SIGN TO BE INSTALLED ON INTERIOR APPROX. 6" BACK FROM STOREFRONT GLASS. CENTER SIGN WITHIN TRANSOM WINDOW.

SIGNINNOVATION



50 Halstead Blvd.
Suite 17
Zellenoople, PA 16063

Tel 724.452.8699
Fax 724.452.8629

www.signinnovation.com



John Koenig, Project Manager
Johnk@SignInnovation.com



- 1 Cover Page
- 2 Site Plan
- 3 Existing Storefront Elevations
- 4 Interior Storefront Sign Details
- 5 Proposed Sign Rendering



Aerie
3235 M St NW,
Washington, DC 20007